

SUBARU Delivers 3,000th Center Wing Box for Large Aircraft

Tokyo, May 26, 2023 - Subaru Corporation today announced that its Aerospace Company has delivered the 3,000th center wing box from the Handa Plant (Handa City, Aichi Prefecture), which was for the Boeing 787.

The center wing box is the section where the wings are attached to the fuselage sections and also serves as a fuel tank.

In addition to the aircraft manufacturing and maintenance, Subaru has expertise in the development and manufacture of the large aircraft compartments such as center wing boxes and main wings as one of its core businesses.

Subaru delivered its first center wing box for Boeing 777 in July 1993. Since then, Subaru has manufactured center wing boxes for five models (Boeing 777, Boeing 787 and Boeing 777X as well as the P-1 maritime patrol aircraft and the C-2 cargo transport aircraft for the Japan Ministry of Defense) at the Handa plant as a one of the world's leading center wing box manufacturing plants using the dedicated production line.

Subaru will continue to strive to further enhance its technologies by always putting quality and safety first, and to provide aircraft systems including total aircraft support such as maintenance and training to our customers in addition to developing and manufacturing aircraft components.



3,000th Center Wing Box Ceremony

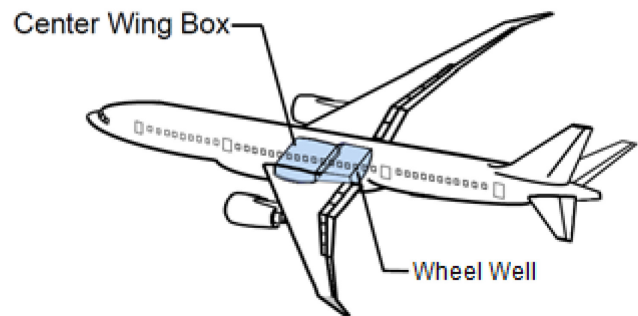

Related news release:

January 8, 2020 – SUBARU delivers 1,000th Center Wing Section for the Boeing 787 Dreamliner

https://www.subaru.co.jp/press/news-en/2020_01_08_8154/

###