



SUBARU

Licensing Opportunities

INTRODUCTION

Subaru Official Licensed Merchandise

Subaru’s Official Licensed Merchandise program offers partners the chance to tap into a wide and diverse audience with access to valuable and compelling brand assets, such as beloved Subaru vehicles and renowned Motorsports drivers.

From motorsports enthusiasts to adventure seekers and lifestyle fans, each category of Subaru Official Licensed Merchandise allows licensees to connect with passionate communities that share a lasting loyalty to the Subaru brand.





Subaru is driven by a commitment to quality, reliability, safety, capability, adventure, excitement and the greater good of our world. From our special lineup of production and motorsports vehicles to award-winning brand advertising, our rich library of iconic assets reflects the love people have for the life they live.

Love. It's what makes Subaru, Subaru.®

Content We'll Cover Today

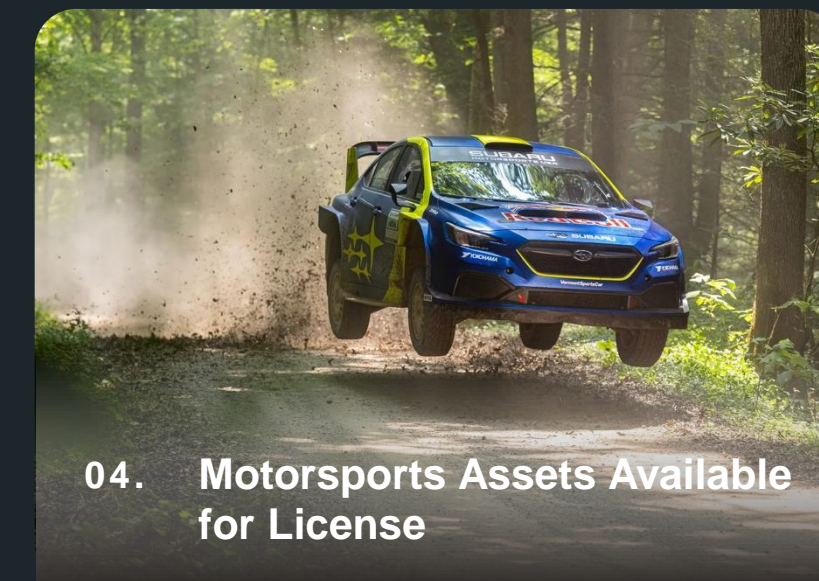
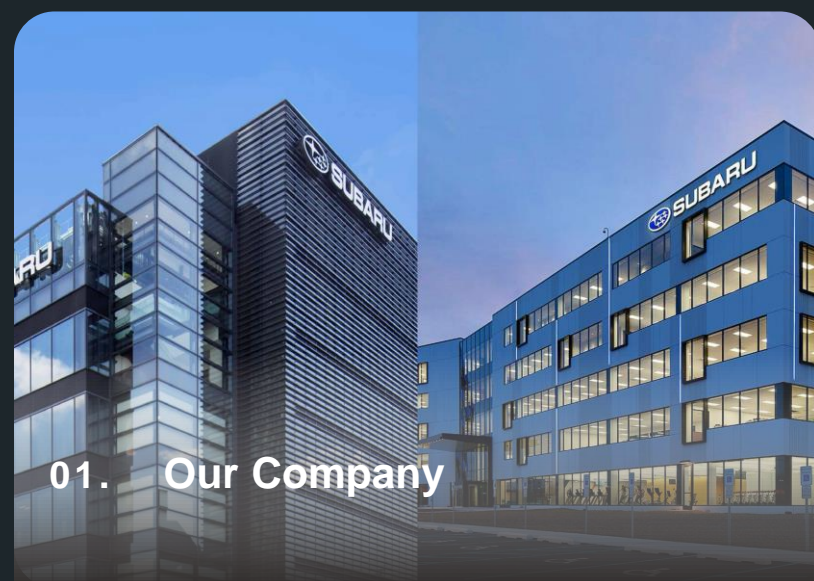

Our Company



Subaru Corporation
Ebisu, Japan

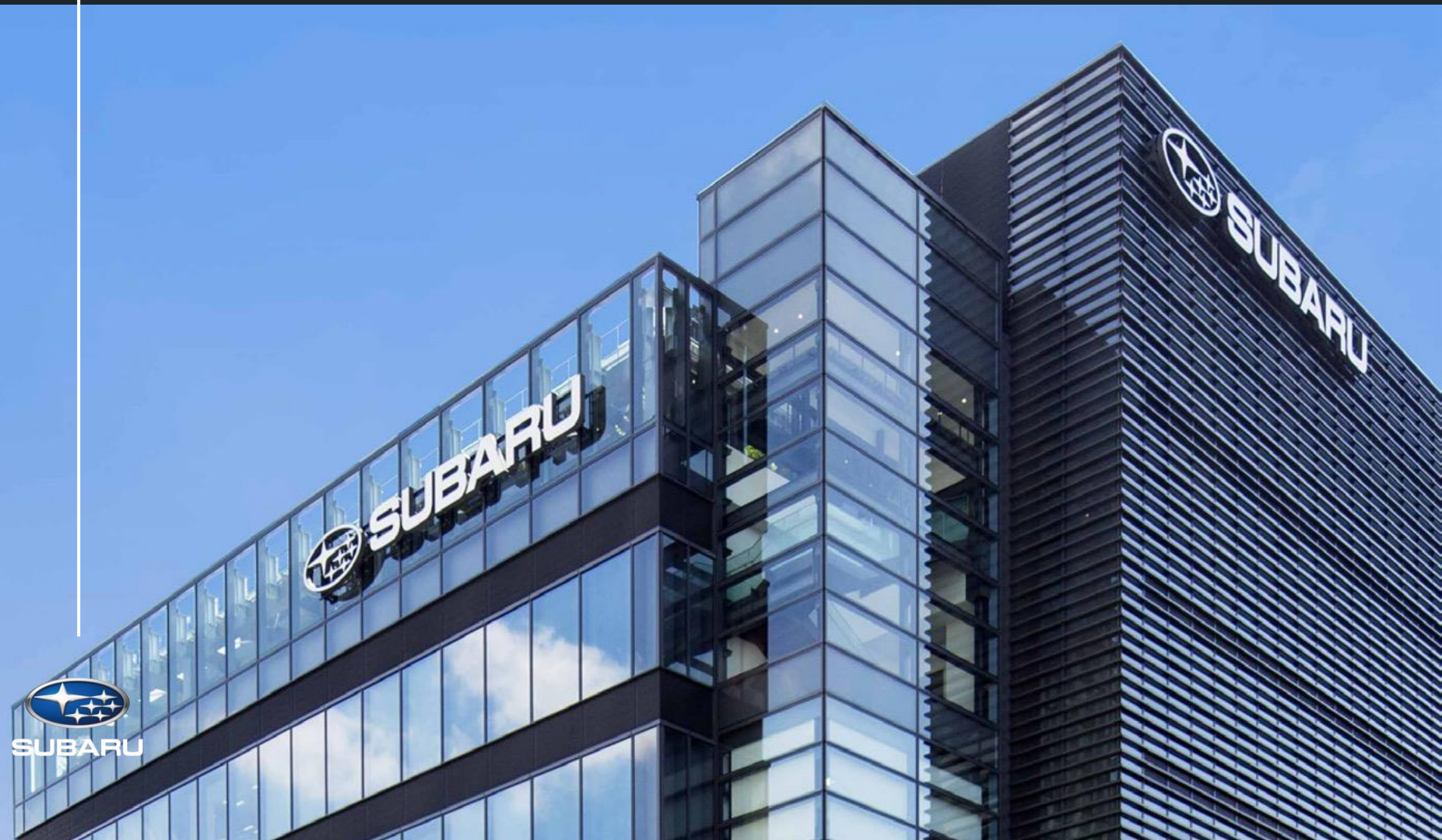

Subaru of America
Camden, NJ



OUR COMPANY – SUBARU CORPORATION

Delivering Happiness to All

In 1953, five Japanese companies merged to form Fuji Heavy Industries Ltd., later renamed Subaru Corporation. Our history as an automaker began with the launch of the Subaru 360 five years later.

Today, Subaru Corporation embodies a global engineering and transportation corporation with an automobile sales network that has locations in 90 countries and regions.



OUR COMPANY – SUBARU OF AMERICA

More Than a Car Company®

Subaru of America is committed to selling and servicing vehicles our customers love, while also being a part of a greater good for our world.

From our Share the Love® Event, to our Love Promise community efforts, we are proud to say that Subaru is More Than a Car Company®.

Subaru of America, Inc.

643

U.S. Retailers

#8

Largest of 42 Auto Brands Sold in the U.S.



The 2025 Best Automotive Brand, according to Consumer Reports.



Forbes' #1 automotive brand for social impact three years in a row..



Best Customer Satisfaction for Dealer Service among Mass Market SUV & Car Owners.



The best-selling all-wheel-drive brand in America for the last 10 years.



#1 in Safety, Product Quality, Customer Satisfaction, Dependability, and Customer Loyalty.

OUR COMPANY – SUBARU OF AMERICA

The Subaru Love Promise[®]

The Subaru Love Promise is our vision to show love and respect to all people at every interaction with Subaru. Through our five core pillars — Environment, Health, Education, Pets, and Community — and the Subaru Share the Love[®] Event, we aim to create change in the areas Subaru and our owners care about the most.

Subaru Impact



\$288M+

Charitable Donations



900K+

Children and Adults Experiencing Homelessness Supported



13M+

Pounds of Hard-to-Recycle Waste Collected and Recycled



350K+

Cancer Patients Supported



750K+

Students in Need Supported



504K+

Animals Adopted, Rescued, and Supported

Largest Corporate Donor to:



Largest Automotive Donor to:



OUR COMPANY

Social Media & YouTube (U.S.)

Subaru of America's strong and growing social media and YouTube presence offers a powerful platform to amplify licensing partnerships.

With millions of followers across platforms and billions of impressions annually, Subaru engages a loyal and diverse audience that spans key demographics.

Followers & Impressions



2.9M

Total Followers

+43%

Y/Y TikTok Follower Growth



2B

Total Impressions

+57%

Y/Y Impression Growth

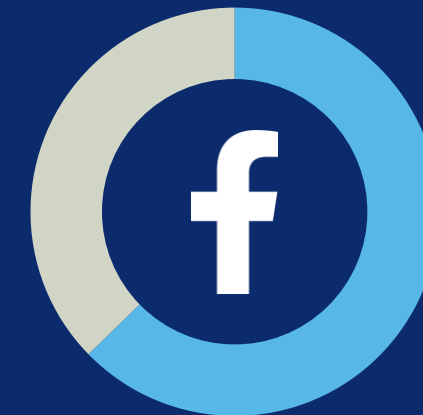

63% Male
37% Female

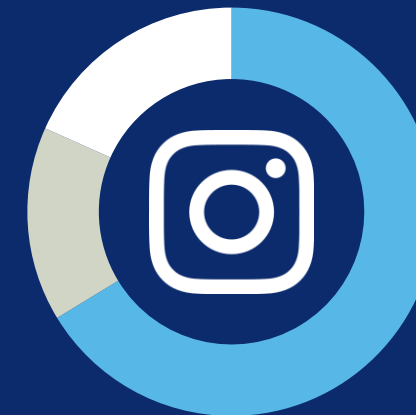

66% Male
15% Female
18% Nonbinary or Unspecified

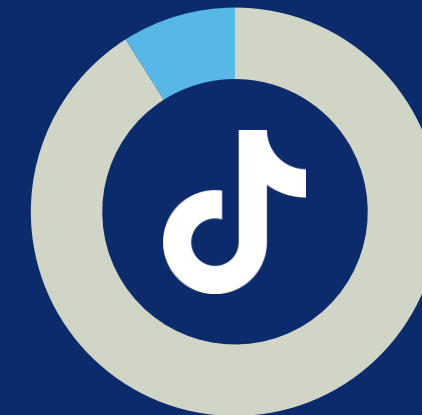

91% Female
9% Male

Ages 25 – 34 most prominent age range across channels



495K+

Subscribers

208M+

Total Video Views



AUDIENCE

SOCIAL MEDIA

Motorsports enthusiasts are among the most engaged on social media, and Subaru leads the way as their top team.

22% HIGHER REACH

than World Rally Championship (WRC) teams from Toyota, Hyundai, and Ford, combined.



Subaru Motorsports USA is #1 in social media reach.

FOLLOWERS & IMPRESSIONS



17.2M

Total Team Followers ¹

+42.6%

Follower Increase Year Over Year ²

488M

Impressions ²

ENGAGEMENT RATE & VIEWS



15X

Better Engagement vs. Avg. Sports Teams Per Post ²

234M

Social Media Video Views ²

DEMOGRAPHICS

Audience split among Facebook (ages 25–34) and Instagram (ages 18–24) ²

91 MALE

9% FEMALE



76% MALE

24% FEMALE



1. Subaru Motorsports USA, Subaru of America Inc, Travis Pastrana, Brandon Semenuk, Scott Speed, and Vermont SportsCar's social media accounts.
2. Subaru Motorsports USA's social media accounts



Current Company Assets Available for License

CURRENT ASSETS AVAILABLE FOR LICENSE

Subaru Brand Logos

The six-star logo represents the guiding light of the Pleiades constellation and has been a powerful symbol of the brand's legacy.

The logo has become a representation of the love and loyalty shared by Subaru drivers to the brand.

Brand Logos



Four-Color, Horizontal Logo

Logos available in four-color, one-color, and two-color variations, either horizontal or vertical.



SUBARU

Four-Color, Vertical Logo



SUBARU

One-Color, Vertical Logo

Vehicle Badge

The logo is also the centerpiece of the iconic badge that adorns every Subaru vehicle.



CURRENT ASSETS AVAILABLE FOR LICENSE

Current US Vehicles

Many more vehicles available for license.

CROSSTREK



FORESTER



OUTBACK



ASCENT



SOLTERRA



UNCHARTED



TRAILSEEKER



BRZ



WRX



IMPREZA



CURRENT ASSETS AVAILABLE FOR LICENSE

Non-US Subaru Vehicles

Many more vehicles available for license.

LEVORG



JUSTY



CHIFFON



**LEVORG
LAYBACK**



**PLEO+
PLUS**



**SAMBAR
VAN**



STELLA



REX



**SAMBAR
TRUCK**



CURRENT ASSETS AVAILABLE FOR LICENSE

Subaru Wilderness[®]

Designed for paths less traveled, the Subaru Wilderness family of vehicles is specifically engineered for tougher and deeper off-road exploration. Since its launch in 2022, Wilderness models have quickly found a home with Subaru's audience of outdoor enthusiasts, becoming a mainstay in the off-roading, overlanding, and adventure spaces.



Logo



2026 Subaru Outback Wilderness



2026 Subaru Crosstrek Wilderness



2026 Subaru Forester Wilderness



CURRENT ASSETS AVAILABLE FOR LICENSE

Subaru Tecnica International (STI)[®]

Subaru Tecnica International (STI), our renowned performance division, embodies the spirit of innovation and engineering mastery. From motorsports to production vehicles, STI has become a symbol of dynamic performance and Subaru's dedication to pushing limits.



Primary Logo



Secondary Logo



Vehicle Badge



STI S210

CURRENT ASSETS AVAILABLE FOR LICENSE

Subaru Engineering Elements

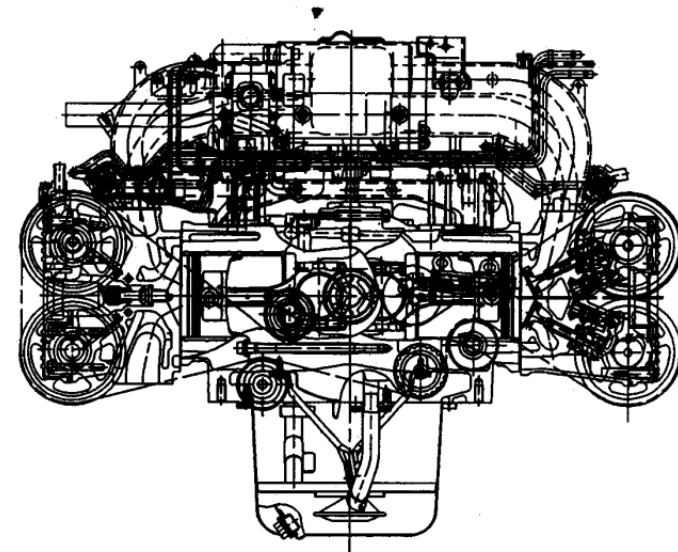
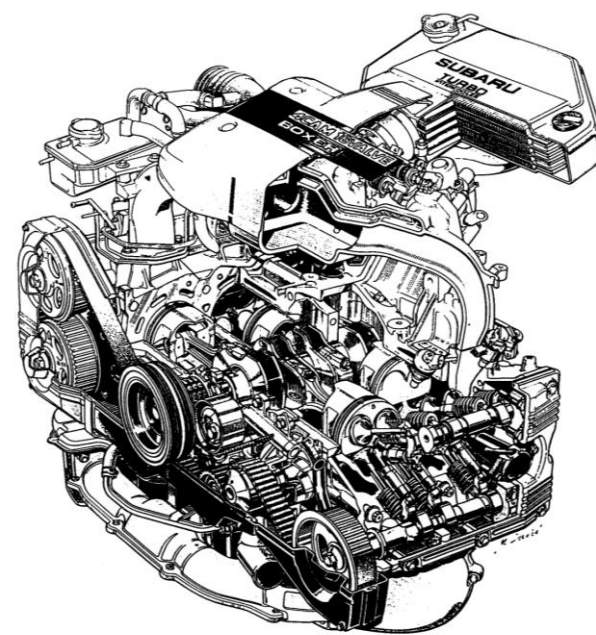

SUBARU BOXER® Engine

The SUBARU BOXER® engine, with its distinctive horizontal layout and balanced design, is a hallmark of the Subaru brand. Its compact and innovative design reflects Subaru's commitment to engineering excellence.



Symmetrical All-Wheel Drive

Recognized as a defining feature of Subaru vehicles, Symmetrical All-Wheel Drive embodies the brand's commitment to confidence and control in all conditions. Its perfectly balanced design has become an iconic element of Subaru's engineering legacy.

CURRENT ASSETS AVAILABLE FOR LICENSE

The Barkleys[®]

Dog tested. Dog approved. The Barkleys, our family of Labrador and Golden retrievers, have been a familiar favorite in our Subaru of America advertising for over a decade.



Vintage Company Assets Available for License

With iconic logos, beloved vehicle designs, and historical advertising, Subaru's vintage collection offers a rich archive of assets that resonate with both brand enthusiasts and those who simply appreciate vintage aesthetics.



VINTAGE ASSETS AVAILABLE FOR LICENSE

Vintage Subaru Brand Logos

Many more vintage brand logos available for license.

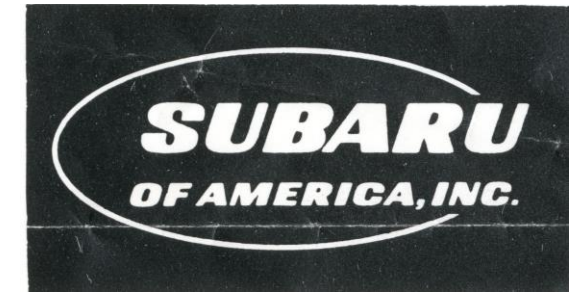

VINTAGE ASSETS AVAILABLE FOR LICENSE

Vintage Subaru Vehicle Badges

Many more vintage vehicle badges available for license.

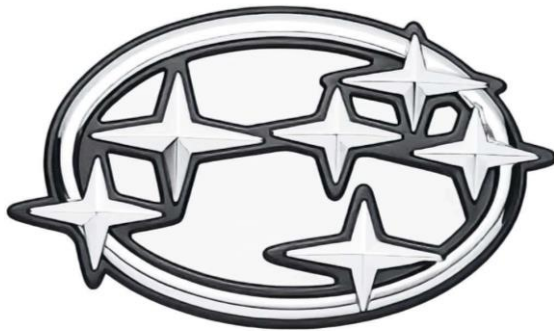
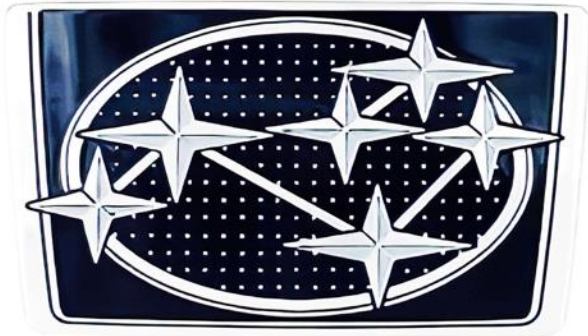
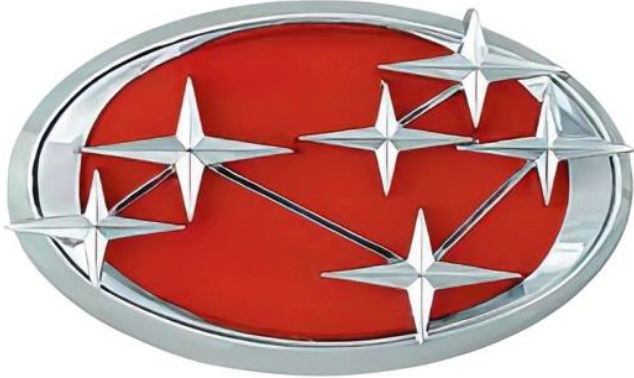

VINTAGE ASSETS AVAILABLE FOR LICENSE

Vintage Subaru Vehicles

Many more vehicles available for license.

Subaru 360



Subaru 360 Van



Subaru 360 Truck



Subaru Sambar



Subaru GL USA Ski Team Wagon



Subaru 22B



2002 Subaru WRX



Subaru XT



Subaru Brat



VINTAGE ASSETS AVAILABLE FOR LICENSE

Vintage Subaru Tecnica International[®] (STI) Vehicles

From iconic engineering to rare, unique models, these STI vintage vehicles have captured the hearts of enthusiasts worldwide, showcasing decades of innovation and performance excellence.

Subaru Impreza 22B STI Version (1998)



Subaru Impreza STI S201 (2000)



Subaru Forester STI II Type M (2001)



Subaru Impreza WRX STI S203 (2004)



Subaru Impreza WRX STI R205 (2010)



Subaru WRX S209 (2019)



Many more STI vehicles available for license.

VINTAGE ASSETS AVAILABLE FOR LICENSE

Vintage Advertising & Slogans

THE SUBARU XT6 TO SAVE MONEY BUY A SUPER BUILT WAGON.

THE KIND OF CAR MERCEDES MIGHT HAVE BUILT IF THEY WERE A LITTLE MORE FRUGAL AND A LOT MORE INVENTIVE.

Contrary to popular belief, an extraordinary car must not cost an extraordinary amount of money. Case in point: the new Subaru XT6. Simply put, the XT6 boasts a combination of features not found on any car. At any price. In fact, it's the only car of its kind to utilize a computerized full time 4 wheel drive system. Under the hood, the XT6 is powered by Subaru's first aluminum alloy overhead cam 6 cylinder engine. Recent innovations like on-board computers and self-adjusting air suspension are also offered. And if you haven't guessed by looking at it, the XT6 is the most aerodynamic car now in production in the world. All of which makes this Subaru's "Mercedes-like" price even more astounding. You can purchase an XT6 for as little as \$9,995. The Subaru XT6. The car that finally ends the myth that high technology may only be purchased at a high price.

SUBARU.
We built our reputation by building a better car.

SUBARU®
To own one is to love one.

SUBARU
THE ECONOMY CAR FOR TODAY'S ECONOMY.

WE'RE CHANGING THE FACE OF 4 WHEEL DRIVE.

SUBARU
INEXPENSIVE. AND BUILT TO STAY THAT WAY.

BEFORE YOU GO ON A TRIP, PUT YOUR VALUABLES IN A SAFE PLACE.

Namely, the Subaru Wagon, the #1 import wagon in America. You see, every Subaru Wagon comes with road gripping front wheel drive. Or the option of either an "On Demand" or full time four wheel drive system for a greater measure of safety and traction. What's more, Subaru has a proven record of reliability, durability and customer satisfaction. Which means the Subaru Wagon isn't just safe on the road, it's safe down the road.

SUBARU.
We built our reputation by building a better car.

Subaru. What to drive.™

SUBARU® 
The Beauty of All-Wheel Drive.®

新型サンバー
ライトバン

54年商用車排出ガス規制及び騒音規制適合

Many more vintage advertisements and slogans available for license.



SUBARU MOTORSPORTS EFFORTS



MOTORSPORTS & SUBARU

Motorsports has cultivated a global fanbase of passionate and knowledgeable enthusiasts, driven by over 50 years of thrilling races, memorable moments, and cutting-edge vehicle technology.

With a rich heritage that spans decades, continents, and four distinct disciplines, Subaru has cemented its place as a motorsports powerhouse, renowned for its iconic vehicles and legendary drivers.

OUR AUDIENCE

Subaru Motorsports reaches large audiences at scale.



SUBARU
MOTORSPORTS USA

AUDIENCE

ONLINE VIDEO

SOUTHERN OHIO
2024

Motorsports **493K**
by Subaru **Subscribers**

Playlist • 187 videos • 100,400 views

▶ Play all



LAUNCH CONTROL
SERIES

7.9M
Minutes Watched



SPECIALTY DEVELOPED
CONTENT

4M+
Views



SUBARU
MOTORSPORTS USA

AUDIENCE

EARNED MEDIA

Subaru Motorsports generates significant media visibility through organic coverage of races, team news, and technological advancements, supported by strategic press releases and driver engagements with fans and media.

JALOPNIK

MOTORTREND

CAR AND DRIVER

ROAD & TRACK

Sports

TopGear

MEN'S JOURNAL

Sports Illustrated

Forbes



THE DRIVE

Watch Travis Pastrana Wrangle the 850-HP Subaru Huckster Up the Goodwood Hill!

MCLAREN'S SOLUS GT TAKES GOODWOOD HILLCLIMB VICTORY BUT TRAVIS PASTRANA'S SUBARU STEALS

DirtFish

SEMENUK WINS EVERY STAGE ON SNO*DRIFT

THE SHOW

DRIVING

Home > News > Auto Events

autoevolution

The Discrepancy Between a Solus GT and a 'Family Huckster' - That's Goodwood FoS

Published: 19 Jul 2023, 07:12 UTC • By: Aurel Niculescu

There is a simple reason why the annual British motorsports festival featuring modern and historic motor racing vehicles has become so unanimously praised and revered – as long as they're entertaining and have (some) wheels, they are allowed in without any stigma.

SEMENUK HUMBLLED BY ARA SUCCESS

AFTER DOMINATING THE 2023 CHAMPIONSHIP, THE CANADIAN STAR HAS HEAPED PRAISE ON HIS SUBARU MOTORSPORTS USA TEAM

DirtFish



GOODWOOD ROAD & RACING

Video: How Subaru built Travis Pastrana's Family Huckster

AUDIENCE

EVENTS & ACTIVATIONS

In the U.S., in-person experiences offer a unique platform for Subaru to bring together dedicated motorsports and brand fans, from interactive experiences and vehicle showcases to Subaru exclusive enthusiast events.

400K+

Estimated Yearly Live Event Attendees

80+ & 200+

Activations at shows, dealerships, and races for 200+ event days each year.

6 OWNER EVENTS

MA, CA, PA, IL, FL, TX



31.4K

Attendees



RALLY



RALLY

WHAT IS IT?

Rally racing takes place across the globe as the World Rally Championship (WRC) and in the U.S. as the American Rally Association (ARA)

A thrilling point-to-point race against the clock, Rally pushes drivers, co-drivers, and their machines to the limit.

Teams race production-based cars on closed public roads day or night, conquering every imaginable terrain, from snowy mountains to muddy forests and sandy deserts, all while tackling high jumps and tight turns at incredible speeds.

Audience Reach

WORLD RALLY CHAMPIONSHIP

4M Fans Attracted

1B+ Global Reach

AMERICAN RALLY ASSOCIATION

40.2M Total Impressions

47% ARA Fans Own a Subaru



SUBARU HISTORY & SUCCESS



RICH HERITAGE

Subaru is the most revered name in rally. Our legacy started over 20 years ago with the Subaru World Rally Team and legendary drivers like Colin McRae, Richard Burns, and Petter Solberg.

CONTINUED LEGACY

Subaru Motorsports USA has continued the legacy of the Subaru World Rally Team since 2008.



3X

MANUFACTURERS' CHAMPION

Three-time winner from 1995–1997.

RALLY CHAMPIONSHIPS

Including wins in 18 of the last 20 Rally Championships with 9-straight wins from 2011-2019 and a clean sweep from 2021-2025.

3X

DRIVERS' CHAMPION

Three-time winner in 1995, 2001, and 2003.



LOGOS & COLORS



SUBARU WORLD RALLY TEAM

The Subaru World Rally Team's iconic blue and gold color scheme remains one of the most recognizable and memorable liveries in World Rally Championship history.



SUBARU MOTORSPORTS USA

The most iconic automotive name in motorsports today with the beloved blue and gold Subaru World Rally Team colors.



SUBARU MOTORSPORTS USA COMET AND STAR CLUSTER

The modern evolution of the original Subaru World Rally Team's comet and star cluster is now being used as part of Subaru Motorsports USA efforts.



RALLY | ASSETS AVAILABLE FOR LICENSE

VEHICLES



2025 SUBARU WRX ARA25L L4WD CLASS RALLY CAR



DRIVER
 + Travis Pastrana

HIGHLIGHTS
 + 2025 ARA Limited 4WD Class Winner

2024 SUBARU WRX ARA24 OPEN CLASS RALLY CAR



DRIVERS
 + Travis Pastrana
 + Brandon Semenuk

HIGHLIGHTS
 + 2024 American Rally Association National Champion (Semenuk)

2022 SUBARU WRX STI OPEN CLASS RALLY CAR



DRIVERS
 + Travis Pastrana
 + Brandon Semenuk

HIGHLIGHTS
 + 2022 and 2023 American Rally Association National Champion (Semenuk)

2012 SUBARU WRX STI OPEN CLASS RALLY CAR



DRIVER
 + David Higgins

HIGHLIGHTS
 + 2012 American Rally Association National Champion

2006 SUBARU IMPREZA WRX STI OPEN CLASS RALLY CAR



DRIVERS
 + Travis Pastrana
 + Ken Block

HIGHLIGHTS
 + 2006 and 2007 American Rally Association National Champion

2006 SUBARU IMPREZA WRX STI X GAMES



DRIVER
 + Colin McRae

HIGHLIGHTS
 + Iconic McRae roll during first televised American rally during the 2006 X Games



RALLY | ASSETS AVAILABLE FOR LICENSE

VEHICLES



2006 SUBARU IMPREZA WRC2006



DRIVER

+ Petter Solberg

HIGHLIGHTS

+ Multiple Podium Finishes
 + 2nd Place Rally of Mexico and Rally of Turkey

2003 SUBARU IMPREZA WRC2003



DRIVER

+ Petter Solberg

HIGHLIGHTS

+ One of our most iconic rally cars
 + 2001 WRC Drivers' Championship

2001 SUBARU IMPREZA WRC2001



DRIVER

+ Richard Burns

HIGHLIGHTS

+ "Bugeye" Design Overhaul
 + 2001 WRC Drivers' Championship

1997 SUBARU IMPREZA WRC97



DRIVER

+ Colin McRae

HIGHLIGHTS

+ Subaru's Third Consecutive WRC Manufacturers' Championship (1997)
 + 1997 WRC Drivers' Championship 2nd Overall

1994-1996 SUBARU IMPREZA 555



DRIVER

+ Colin McRae

HIGHLIGHTS

+ Subaru's First WRC Manufacturers' Championship (1995)
 + 1995 WRC Drivers' Championship

1993 SUBARU LEGACY RS



DRIVER

+ Colin McRae

HIGHLIGHTS

+ Subaru's entry into the WRC, winning its first rally at the 1993 New Zealand Rally.



RALLY | ASSETS AVAILABLE FOR LICENSE

RALLY DRIVERS

CAR #199



TRAVIS PASTRANA

- + 6x ARA National Champion (2006 – 2009, 2017, 2021)
- + Driver Name, Image, and Likeness available for license.

CAR #180 (Former Driver)



BRANDON SEMENUK

- + Defending 4x ARA National Champion
- + 5x Canadian Rally Champion
- + Driver Name, Image, and Likeness available for license.

HEAD TO “MEET THE DRIVERS” SECTION FOR MORE ON PASTRANA AND SEMENUK



LICENSING OPPORTUNITIES

RALLYCROSS



RALLYCROSS

WHAT IS IT?

Rallycross is an exciting motorsport that combines the best aspects of rallying and circuit racing. Drivers compete on short, mixed-surface circuits that include both asphalt and gravel or dirt, creating a unique challenge with ever-changing conditions.

Unlike rally cars, rallycross vehicles are built for speed and don't have to be street legal, allowing for faster, more aggressive racing. With tight corners, jumps, and frequent contact between cars, the action is intense and unpredictable, making every race a thrilling spectacle for both drivers and spectators.

Audience Reach

216K

Views on Subaru Launch Control's episode of the 2021 Nitro Rallycross' final event



SUBARU HISTORY & SUCCESS



RALLYCROSS REIGN

Subaru was a dominant force in rallycross. Our rallycross journey began in 2012 with the Global Rallycross Championship, and we went on to continue to push the limits of performance in America with drivers like Scott Speed and Travis Pastrana, solidifying our place at the forefront of rallycross competition.

15+

YEARS OF SUBARU RALLYCROSS PERFORMANCE



The inclusion of rally in the X Games 15 years ago elevated the sport to a new level. Our team helped make it happen while earning 10 X Games medals along the way.



RALLYCROSS CHAMPIONS

Winners of both the 2021 Nitro Rallycross Team and Driver's Championships, and the 2019 America's Rallycross Team's Champion.

RALLYCROSS | ASSETS AVAILABLE FOR LICENSE

VEHICLES



2021 SUBARU WRX STI RALLYCROSS SUPERCAR



DRIVERS

- + Travis Pastrana
- + Scott Speed

HIGHLIGHTS

- + 2021 Nitro Rallycross Team Championship and 1st and 2nd place in Driver's Championship

2017 SUBARU WRX STI RALLYCROSS SUPERCAR



DRIVERS

- + Patrik Sandell (Gray/Yellow Livery)
- + Chris Atkinson (Blue/Yellow Livery)

HIGHLIGHTS

- + Several 2017 Red Bull Global Rallycross Championship Podium Finishes

2015 SUBARU WRX STI RALLYCROSS SUPERCAR



DRIVERS

- + Bucky Lasek (Gray Livery)
- + Sverre Isachsen (White Livery)

HIGHLIGHTS

- + Competed in 2015 Los Angeles Global Rallycross Championship as special one-off livery

2011 SUBARU IMPREZA WRX STI RALLYCROSS SUPERCAR



DRIVER

- + BMX Legend Dave Mirra

2010 SUBARU IMPREZA WRX STI RALLYCROSS SUPERCAR



DRIVER

- + Travis Pastrana

HIGHLIGHTS

- + Competed in first ever Rallycross events held in US in 2010



RALLYCROSS DRIVERS

CAR #199



TRAVIS PASTRANA

- + World famous action sports athlete, driver, stuntman
- + Nitro Rallycross founder
- + 2021 Nitro Rallycross Driver's Champion
- + Driver Name, Image, and Likeness available for license.

CAR #41

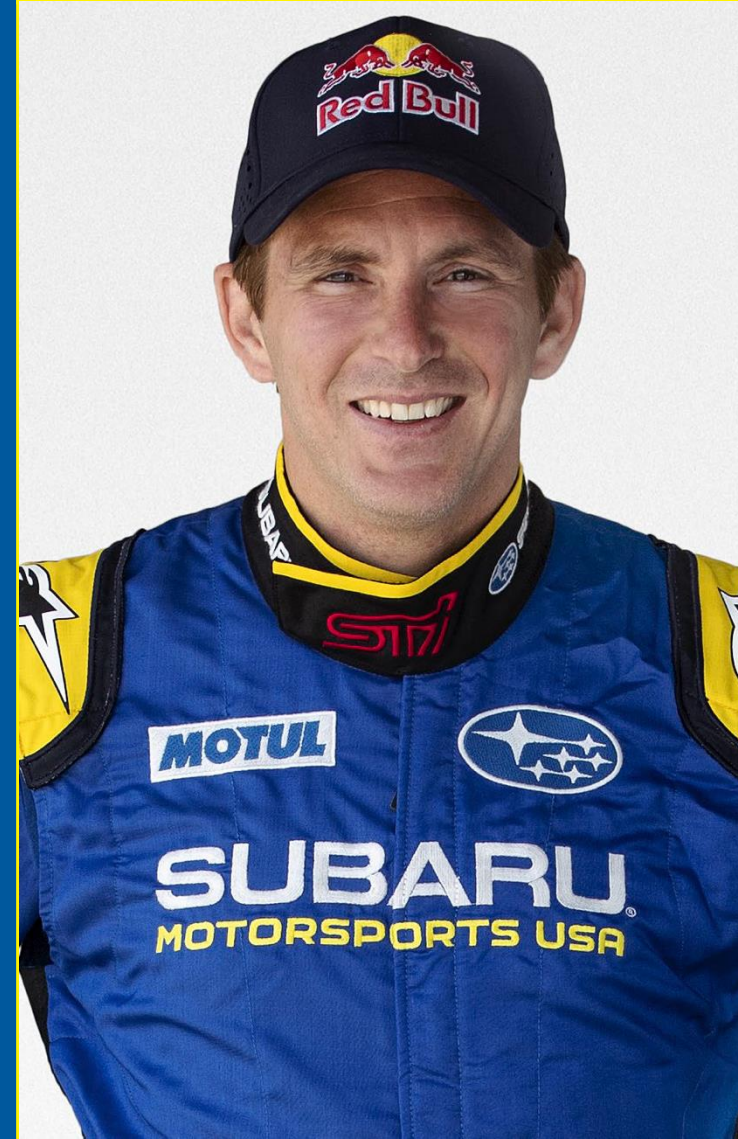

SCOTT SPEED

- + Ex-Formula 1 Driver with Four Straight US Rallycross Championship Titles (2014-2018)
- + Driver Name, Image, and Likeness available for license.

HEAD TO "MEET THE DRIVERS" SECTION FOR MORE ON PASTRANA AND SPEED



GYMKHANA



GYMKHANA

WHAT IS IT?

Gymkhana is an exciting, high-octane automotive stunt series that has captivated audiences worldwide. Featuring purpose-built vehicles, the series showcases thrilling stunts and driving precision in environments like the steep streets of San Francisco or abandoned factories in Detroit. Each video combines drifting, tight turns, and jumps in fast-paced sequences, highlighting the power of the cars and the skill of the drivers.

The video series has become a fan favorite, with millions tuning in to watch the jaw-dropping action, making Gymkhana a must-see spectacle in motorsport entertainment.

Audience Reach

505M+

Over the 12 installments of the viral Gymkhana video series



SUBARU HISTORY & SUCCESS



POWERING GYMKHANA ACTION

Subaru was there to kick off the viral Gymkhana video series with Ken Block's first two videos in 2008 and 2009 and now Subaru Motorsports USA and Travis Pastrana continue to bring the iconic Gymkhana videos to life for millions of fans across the world.

GYMKHANA 2008

17M+ Views

46K+ Likes

GYMKHANA 2009

53M+ Views

171K+ Likes

GYMKHANA 2020

67M+ Views

1.1M+ Likes

GYMKHANA 2022

23M+ Views

533K+ Likes

GYMKHANA 2025 NOW LIVE!

VEHICLES



2020 SUBARU "AIRSLAYER" STI



DRIVER

+ Travis Pastrana

HIGHLIGHTS

- + Custom built for and starred in "Gymkhana 2020" viral video with 72M+ YouTube views
- + Record Holder: Mt. Washington Hillclimb
- + Record Holder: Virginia International Raceway (Grand Course) (Scott Speed)

1983 SUBARU GL FAMILY HUCKSTER



DRIVER

+ Travis Pastrana

HIGHLIGHTS

- + Custom built for and starred in "Gymkhana 2022" viral video with 27M+ YouTube views
- + Multiple podium finishes at Goodwood Festival of Speed Hillclimb Shootout



VEHICLES



1978 Subaru Brataroo 9500 Turbo



DRIVER

- + Travis Pastrana

HIGHLIGHTS

- + Custom built for and starred in “Gymkhana 2025”
- + bodywork shaped by acclaimed designer Khyzyl Saleem (The Kyza)
- + Spiritual prequel to the Huckster, blending heritage and innovation in equal measure.



LICENSING OPPORTUNITIES

EXHIBITION



EXHIBITION

WHAT IS IT?

In these events, drivers don't race directly against each other but instead take on the clock, aiming for the fastest time over challenging courses, whether on a winding mountain road or a dedicated racetrack.

Each run is a test of precision, skill, and engineering, where even a fraction of a second can be the difference between victory and defeat. Drivers face not only the terrain and time but also the pressure of chasing records set by their rivals and even themselves.

Audience Reach

200K

Fans attended the Goodwood Festival of Speed in England.

155K

Fans enjoy the thrill of motorsports in downtowns across the country with Red Bull Show Runs.



SUBARU HISTORY & SUCCESS



SETTING RECORDS

Subaru has broken speed and time records at renowned events and locations like the Isle of Man TT, Mt. Washington, and the Goodwood Festival of Speed with turbocharged vehicles that showcase our performance and engineering excellence in motorsports worldwide.

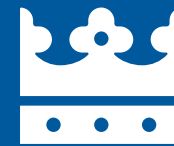

Scott Speed in Subaru's Project Midnight, set the fastest internal combustion vehicle time at the 2024 Goodwood Festival of Speed.

11M

Our Goodwood Festival efforts earned 881K+ engagements and 11M+ impressions on SMSUSA social accounts.



Current Mt. Washington Climb to the Clouds record, set by Travis Pastrana in 2021 with the Subaru Airslayer STI.



Lap record for Car and Driver's Lightning Lap at Virginia International Raceway set by Scott Speed in the Subaru Airslayer STI.

EXHIBITION | ASSETS AVAILABLE FOR LICENSE

VEHICLES



2024 SUBARU WRX: PROJECT MIDNIGHT



DRIVER
+ Scott Speed

HIGHLIGHTS
+ Fastest Internal Combustion Engine Car at Goodwood Hillclimb 2024
+ Velocity Invitational 2024 Winner: Global Time Attack and Hillclimb

2021 WRX STI RALLYCROSS CAR



DRIVER
+ Scott Speed

HIGHLIGHTS
+ Featured at Red Bull F1 Show Run demos for hundreds of thousands of fans across the country.

2017 SUBARU WRX STI TYPE RA NBR SPECIAL



DRIVER
+ Richie Stanaway

HIGHLIGHTS
+ New Lap Record for Four-Door Sedan at Famous Nürburgring Nordschleife Racetrack

2015 SUBARU WRX STI TIME ATTACK



DRIVER
+ Mark Higgins

HIGHLIGHTS
+ Broke the 37 Mile Isle of Man TT Road Course Record



MEET THE DRIVERS



RALLY, RALLYCROSS, GYMKHANA
& EXHIBITION

TRAVIS PASTRANA

199

One of action sports' most iconic athletes.

Travis Pastrana's accomplishments are extraordinary: he became the motocross World Freestyle Champion at just 14 and is the most decorated competitor in X Games freestyle motocross history. Since starting his rallying career with Subaru in 2004, he has won six rally championships (2006-2009, 2017, and 2021).

Pastrana also co-created Nitro Circus, the biggest live action sports show ever, attracting over 46 million TV viewers in the U.S. and selling more than 750,000 tickets globally.



6.7M FOLLOWERS



5M+ FOLLOWERS



351K SUBSCRIBERS

- + Six-time national stage rally champion (2006-2009, 2017, 2021)
- + Gymkhana series driver, delivering high-flying stunts and precision maneuvers for millions of fans.
- + 2021 Nitro Rallycross Driver's Champion
- + Current record holder, Mt. Washington Hillclimb
- + Nitro Rallycross founder and track designer
- + Most successful freestyle motocross athlete in history
- + Red Bull Athlete (2009 – 2016, 2019 – 2022)



RALLY

BRANDON SEMENUK

(Former Driver)



The world’s best freeride mountain biker also dominates on four wheels.

Semenuk’s talent on a mountain bike is unprecedented - and he brings the same focus and talent that made him a champion on a bike to the world of rally.

A native of British Columbia, Semenuk began rallying in 2010 at a grassroots level, gaining experience, confidence and speed to become one of rally’s rising stars. Subaru recognized his talent and signed him to the team in 2020. Since then, Semenuk has dominated the ARA, winning three rally championships with Subaru.



365K FOLLOWERS



697K FOLLOWERS



18K SUBSCRIBERS

- + Red Bull athlete
- + Four-time American Rally Association (ARA) Champion (2022 – 2025)
- + Five Canadian Rally Championship event wins
- + Three North American Rally Cup titles
- + X Games silver - Mountain Bike Slopestyle (2013)
- + Five-time Red Bull Joyride winner (2011, 2013 – 2015, 2017)
- + Four-time Red Bull Rampage winner (2008, 2016, 2019, 2021)



RALLYCROSS & EXHIBITION

SCOTT SPEED



America's Rallycross King

Since winning the first rallycross race he entered back in 2013, Scott Speed has cemented himself as the undisputed king of American rallycross. He has dominated the sport, winning four straight US rallycross championship titles (2014-2018). Speed has an impressive history in racing: in 2006 he became the first American to race in Formula One since Mario Andretti in 1993. He spent two years in F1 with the Red Bull Toro Rosso F1 team before shifting to NASCAR.

Subaru welcomed the legendary driver to the team in 2019. In 2021 Speed finished 2nd Overall in the Nitro RX Supercar Championship, behind his teammate Pastrana.



78K+ FOLLOWERS



76K+ FOLLOWERS

- + Red Bull Athlete
- + Driver: Project Midnight WRX
- + Four-Straight Rallycross Championships (2014-2018)
- + 2015 X-Games Rallycross Gold Medalist
- + A multi-disciplined veteran athlete with experience in F1, NASCAR, IndyCar, and Formula E
- + Track Record Holder: Virginia International Raceway





CONTACT OUR TEAM

LICENSING OPPORTUNITIES RELATED
TO **SUBARU**

HO-SUBARU-LICENSING@SUBARU.CO.JP

**Yoshihide
Yano**

yano.yoshihide@subaru.co.jp

1-20-8 Ebisu, Shibuya-ku, Tokyo , 150-8554, JAPAN