

# SERVICE BULLETIN



FUJI HEAVY INDUSTRIES LTD.

JCAB APPROVED

HEAD OFFICE ; SUBARU BLDG.  
SHINJUKU, TOKYO, JAPAN

NO. 200-005

DATE 1-10-1984

(SUPERSEDES NO. )

REV.

DATE

(SUPERSEDES NO. )

REASON

1. SUBJECT : Introduction of Teijin Seiki Service Bulletin No. TS-SB-72 (Inspection and Modification of Teijin Seiki Fuel Strainer P/N FIF-40000)
2. AIRCRAFT AFFECTED : All FA200-160, 180 and 180A aircraft equipped with fuel strainer specified by Teijin Seiki S.B. No. TS-SB-72.
3. PRIORITY : Mandatory
4. REASON : There have been instances reported whereby the stack pipe inside the subject fuel strainer became lodged upwards into the fuel inlet gallery, thus restricting the fuel flow. This is to introduce S.B. No. TS-SB-72 issued by Teijin Seiki Co. Ltd., to prevent partial engine failure due to restriction of fuel flow.
5. DESCRIPTION : Accomplish the following in accordance with Teijin Seiki S.B. No. TS-SB-72:
  - a) For fuel strainers S/N 445 thru 504 and S/N unknown strainers, check for applicability of S.B. No. TS-SB-72:
  - b) For fuel strainers prior to S/N 445 and affected strainers determined by the above a), check and determine when modification must be accomplished.

## NOTE

If discrepancy is noted, modify fuel strainer before next flight.

6. ACCOMPLISHMENT : Accomplish the following in accordance with Teijin Seiki S.B. No. TS-SB-72:
  - a) Accomplish inspection upon receipt of the bulletin, and, if discrepancy is noted, modify fuel strainer before next flight.
  - b) For serviceable fuel strainers, accomplish modification within next 25 flight hours.

AIRCRAFT DIVISION

1-11 YOUNAN 1 CHOME, UTSUNOMIYA TOCHIGI JAPAN 〒320  
TEL 0286 (58) 1111 TELEX 3522 176

SERVICE BULLETIN 200-005

PAGE 1 OF 2

7. APPROVAL : JCAB approval (No-Tokyo-58-001) December 24, 1983
8. PARTS REQUIRED : See the attached S.B. No. TS-SB-72
9. SPECIAL TOOL : None required.
10. WEIGHT AND BALANCE: Not affected.
11. REFERENCE : Teijin Seiki S.B. No. TS-SB-72
12. DETAILED INSTRUCTIONS: See S.B. No. TS-SB-72
13. COMPLIANCE RECORD : After modification has been completed,
  - a) Reidentify fuel strainer by adding "A" to fuel strainer serial number.
  - b) Make a logbook entry to indicate completion of inspection and modification.

# SERVICE BULLETIN

JCAB APPROVED

TEIJIN SEIKI CO., LTD.  
GIFU PLANT,

NO. TS-SB-72      DATE 1-10-84  
REV                      DATE  
                            REASON

1110-1 Miyashiro, Tarui-cho  
Fuwa-gun, Gifu-ken, 503-21  
Japan

## 1. Subject

Phase 1 : Inspection of FIF40000 Fuel Strainer, for prevention of fuel-blockade.

Phase 2 : Repair of FIF40000 Fuel Strainer, for prevention of fuel-blockade.

## 2. Aircraft Affected

Phase 1 : All aircraft equipped with any of; Fuel Strainer of S/N before 504 inclusive, or S/N of which is unidentifiable.

Phase 2 : All aircraft equipped with any of; Fuel Strainer of S/N before 444 inclusive, Fuel Strainer, to which repair work is required in view of its configuration as shown in Fig-1, among those of S/N 445 to 504 both inclusive, or Fuel Strainer S/N of which is unidentifiable.

NOTE: Phase 1 and Phase 2 do not apply to Fuel Strainers of S/N on and after 505.

## 3. Priority

mandatory

## 4. Reason

In connection with some particular model of FIF40000 Fuel Strainer, there is slight chance of its piece part; FIF40008 pipe becoming loose in the body, which might result in fuel-blockade.

Therefore,

Phase 1; each of applicable Fuel Strainers shall be first inspected to determine whether and when repair work is

required, and

Phase 2; each of applicable strainers shall be repaired to prevent pipe loosening.

5. Description

Phase 1 : All strainers defined in paragraph 2 Phase 1 shall be inspected and determined by configuration whether repair work is required according to Fig-1.

All Fuel Strainers, requiring repair as a result of above inspection, shall be repaired per Phase 2 procedure within next 25 flight hours, except Fuel Strainer which exhibits condition described below shall be repaired before next flight.

Condition; loose pipe and/or pipe which projects less than 62mm from the surface of the body.

Phase 2 : The repair work is to replace the pipe with FIF40020 pipe.

6. Accomplishment

Phase 1 : Immediately after the receipt of this service bulletin.

Phase 2 : Within 25 flight hours or before next flight after Phase 1 inspection, depending on the result of Phase 1 inspection.

7. Approval

JCAB Approval (No. -TOKYO-58-001) Dec. 24, 1983

8. Parts Required.

P/N	NAME	QTY	REMARKS
FIF40020	PIPE	I	Phase 1
MS20995C32	LOCK WIRE	AR	Phase 1 & Phase 2

9. Special Tool

None

10. Weight and Balance  
Negligible

11. Reference  
None

12. Detailed Instruction (Reference : Fig-2)

Phase 1 - Inspection of FIF40000 Fuel Strainer

- 1) Remove and discard lockwire from bolt (1).
- 2) Untighten bolt (1), tilt bracket (2) and remove cover (3), packings (4) (10), barrel (5), washer (6) and screen (7).
- 3) Check pipe and body as is in assembled condition, according to Fig.-1, to see if repair work is required by its configuration.
- 4) For pipe and body which have been determined to be repaired, further inspection shall be conducted as follows.
  - a. Check the interference fit area of pipe and body for looseness by pulling and pushing the pipe.

NOTE: Pull and push force shall be approximately 50g and no extreme force shall be applied.
  - b. Measure and record the pipe projection length.  
(See Fig.-1)

Pipe and body, which have been determined not to be repaired, shall be reassembled as per paragraph 7) and 8).

- 5) If the pipe is loose (moving up and down by above pulling and pushing procedure), and/or the pipe projection length is less than 62mm, Phase 2 repair work shall be accomplished before next flight.  
If there is not evidence of any of above condition, the strainer may be reassembled as per paragraph 7) and 8) for additional flight usage, but shall be

repaired within next 25 flight hours.

- 6) For the strainer which has been checked and determined not to be repaired in paragraph 3) and the strainer which has been determined to be repaired but does not bear evidence of loose pipe or of short pipe projection length (less than 62mm), reassembling process shall be as follows.
- 7) Clean and reassemble parts that have been removed in paragraph 2). Tighten bolt (1) to the torque of 15-20 IN.LBS.
- 8) Apply lockwire on bolt (1)

#### Phase 2 - Repair of FIF40000 Fuel Strainer

- 1) Remove and discard lockwire from bolt (1).
- 2) Untighten bolt (1), tilt bracket (2) and remove cover (3), packings (4) (10), barrel (5), washer (6) and screen (7).
- 3) Pull out pipe (9) from body (8).
- 4) Check and clean the hole in the body (8) and insert the replacement pipe (P/N FIF40020) into the hole by pressing or by tapping it with a plastic hammer, until a shoulder on the pipe comes in contact with the surface of body (8).  
Clean the parts. (Reference : Fig.-3)
- 5) Clean and reassemble the parts that have been removed in paragraph 2). Tighten bolt (1) to the torque of 15-20 IN.LBS.
- 6) Apply lockwire on bolt (1).

#### 13. Others

At the completion of Phase 2 repair work, stamp "A" with permanent ink at the tail of the serial number marking.

Strainer, repair work not required

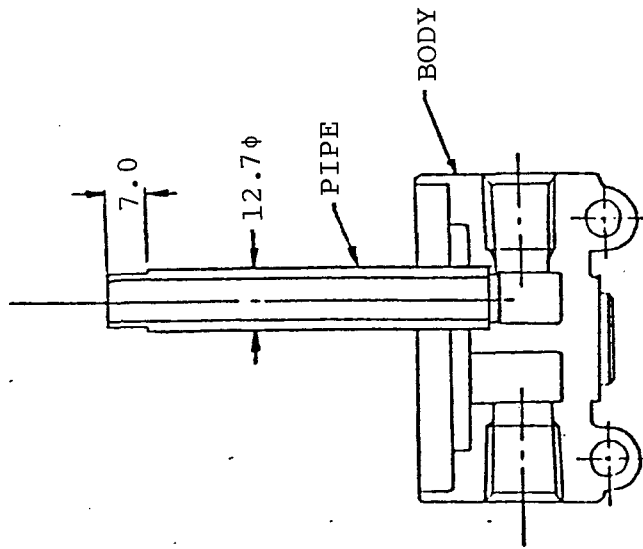

Strainer, repair work required

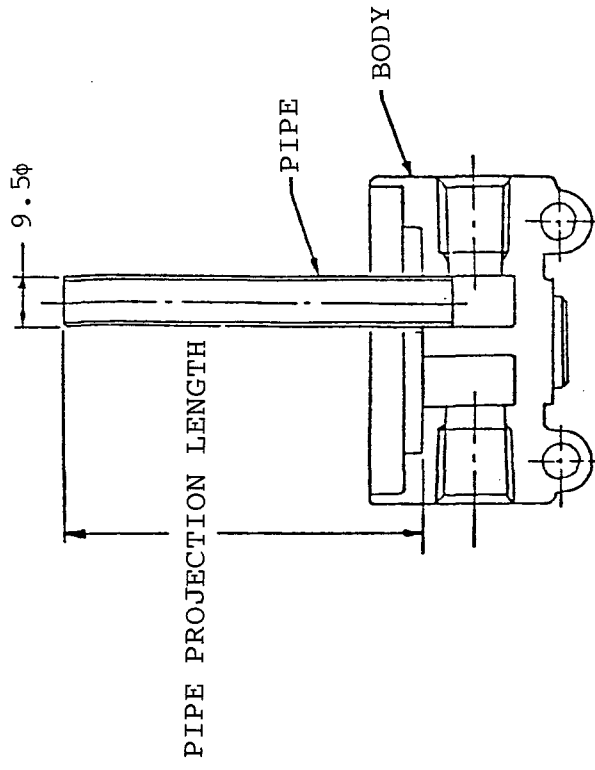

(mm)

Fig.-1

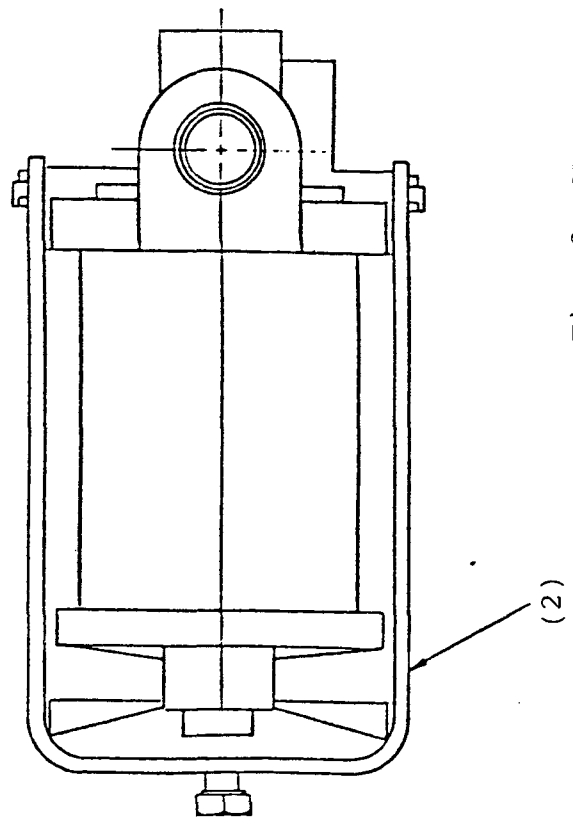
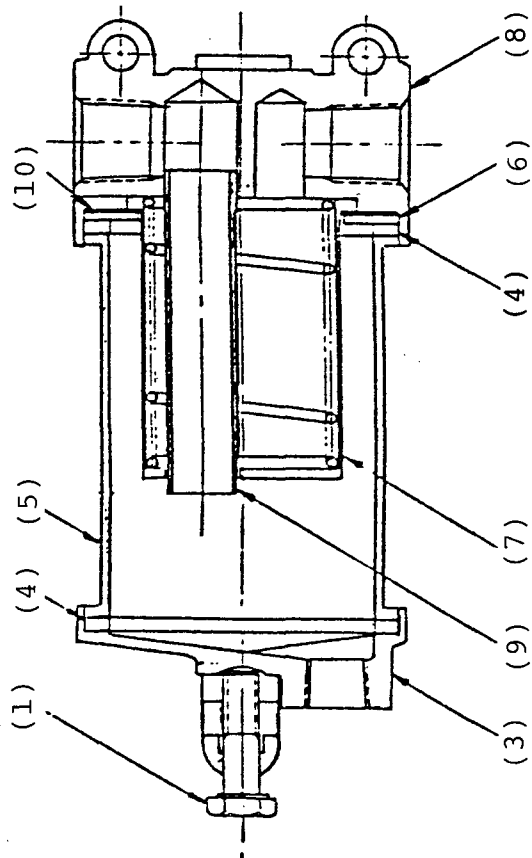

NO	NAME	P/N
1	BOLT	AN4CH7A
2	BRACKET	FIF40004
3	COVER	FIF40002
4	PACKING	FIF40012
5	BARREL	FIF40003
6	WASHER	FIF40011
7	SCREEN	FIF40006
8	BODY	FIF40001
9	PIPE	FIF40008
10	PACKING	FIF40016

Fig.-2 STRAINER ASSEMBLY (before repair)



(mm)

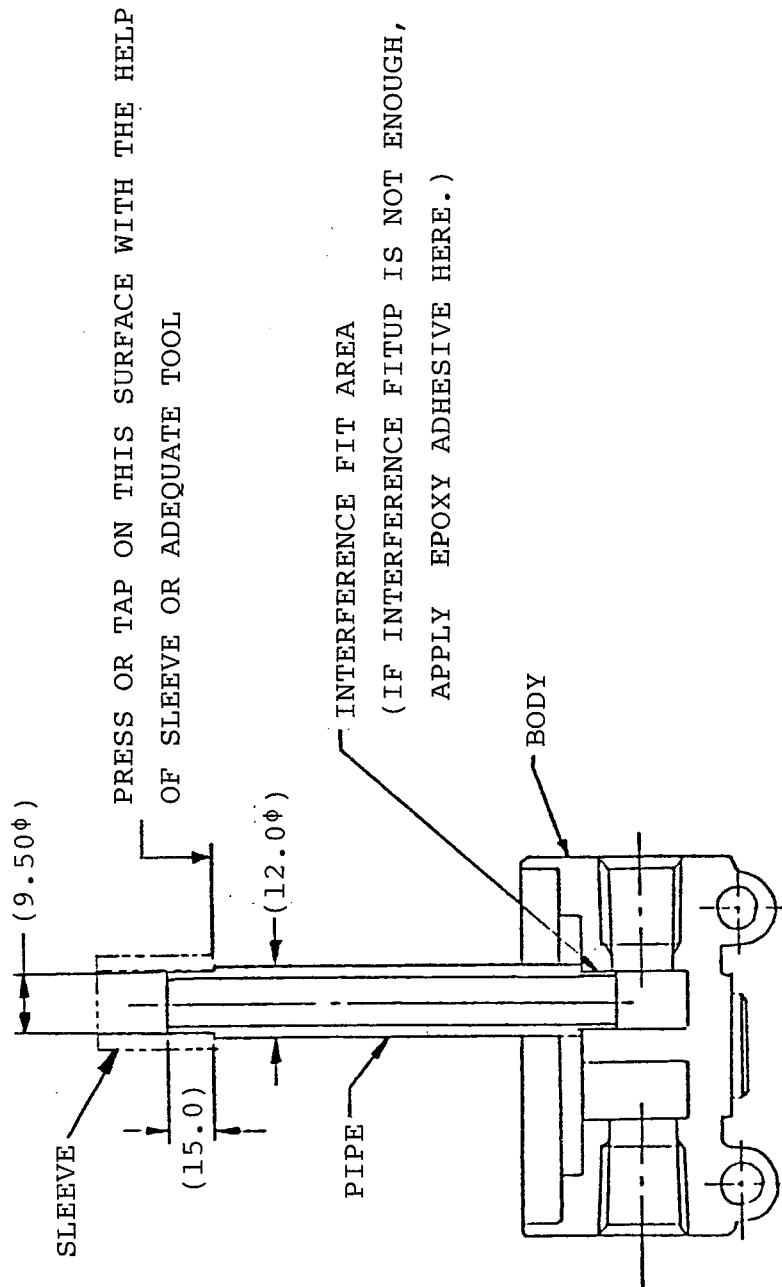

Fig.-3 REPAIR WORK ADVICE