

S E R V I C E B U L L E T I N

Fuji Heavy Industries, Ltd.

NO. FAS-025

DATE May 8, 1970

1. SUBJECT : To burr the canopy rail.
2. AIRCRAFT AFFECTED : FA-200 Serial No. 1 through 86 airplanes.
3. PRIORITY : Desirable.
4. REASON : The rails are burred and chamfered to prevent hand's injury for the canopy top rail.
5. DESCRIPTION : Chamfer the exposed portion (especially front area) of the canopy top rail with proper file and make the smooth radius as far as possible. Finish the surface with some sand papers.

 (Refer to the illustration)
6. ACCOMPLISHMENT : At any time.
7. APPROVAL : Not Applicable.
8. PARTS REQUIRED : None.
9. SPECIAL TOOLS : No Required.
10. WEIGHT AND BALANCE : No change.
11. REFERENCE : None.
12. MANPOWER : Slightly.

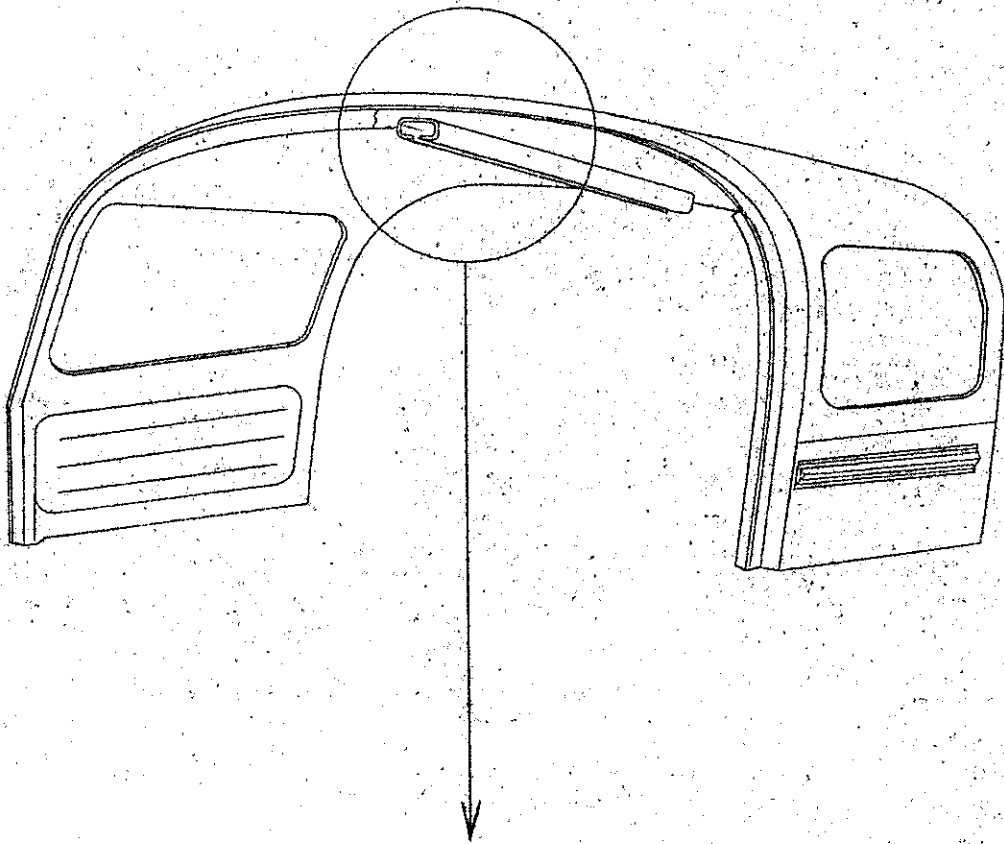

Remove All Burrs
and Sharp Edges.

Section of, Canopy Ceiling Rail