

FIELD SERVICE NEWS

Fuji Heavy Industries, Ltd.
Main Office - No. 1-7,
2-chome, Tsunohazu,
Shinjuku-ku, Tokyo, Japan
Phone: 03-343-5311

FAN-008

Date: April 31, 1970

Aircraft Division

Utsunomiya Work No. 680
Nishihara-cho, Utsunomiya City,
Tochigi Prefecture, Japan
Phone: 0286-58-1111

FA-200 JACK SET

Jack set is prepared for your use to jack up FA-200 landing gear and replace or maintain the wheel, tire and tube.

The jack set will be supplied as a kit (kit number 200-590065-001) which include the parts as follows;

200-590065-003	JACK ASSY	1 ea.
200-590065-005	JACK HANDLE	1
200-590066-003	ADAPTER JACK	1
200-590016-003	PAD-MAIN WHEEL	1
200-590017-003	PAD-NOSE WHEEL	1

It costs 8,300 yen (22,000) as a total.

200-590066-003
ADAPTER-JACK

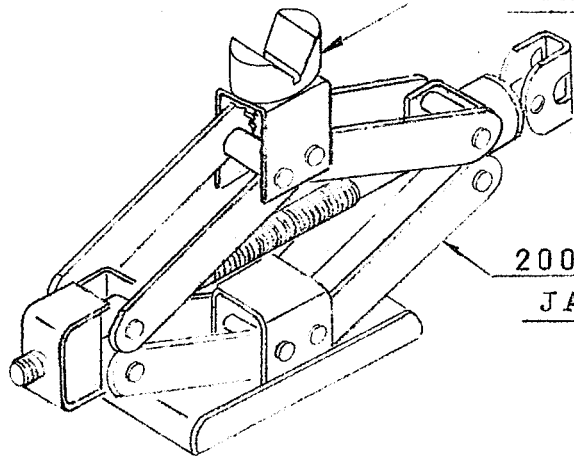

200-590065-003
JACK ASSY

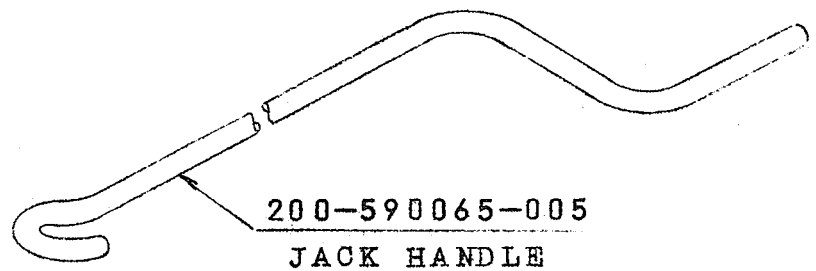

200-590065-005
JACK HANDLE

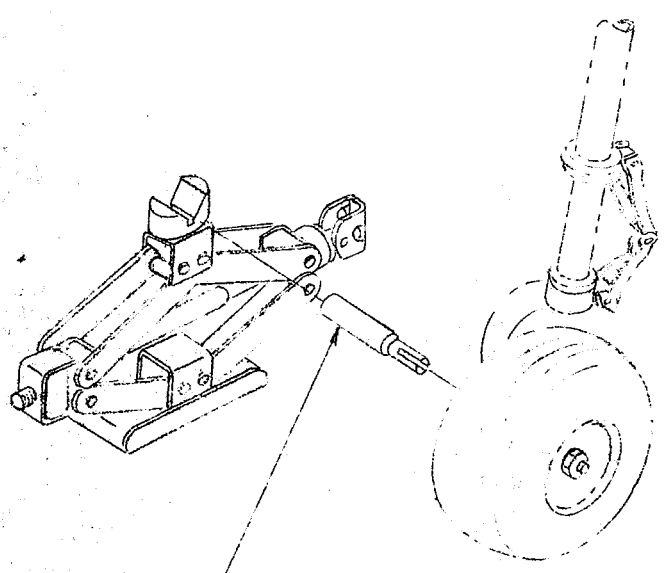

200-590017-003
PAD-NOSE WHEEL

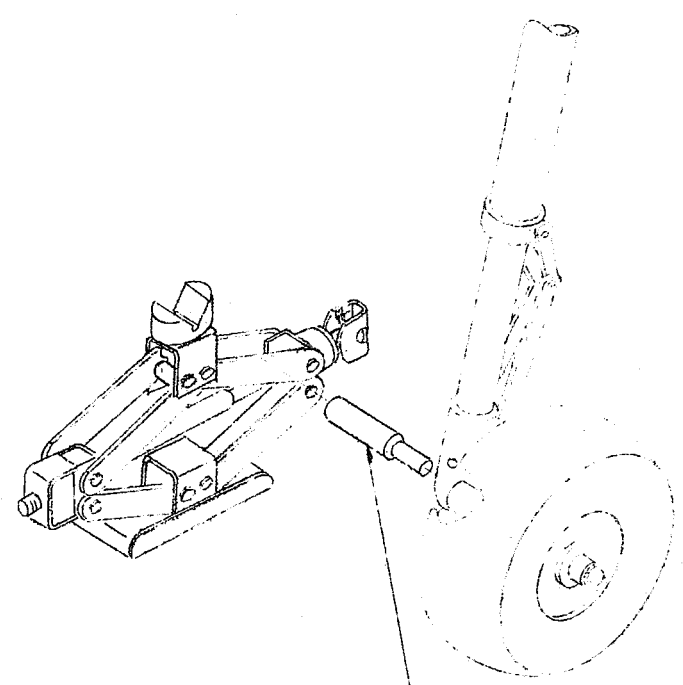

200-590016-003
PAD-MAIN WHEEL